

6277 TAYLOR DRIVE

WEST VANCOUVER, BC

MAIN	1,405 SQ.FT.	GARAGE	388 SQ.FT.
UPPER	1,434 SQ.FT.	BALCONY	548 SQ.FT.
LOWER	1,069 SQ.FT.	DECK	279 SQ.FT.
TOTAL	3,908 SQ.FT.	HOT TUB	263 SQ.FT.
UNFINISHED	128 SQ.FT.	TOTAL	1,478 SQ.FT.
TOTAL AREA	4,036 SQ.FT.		

ND NEACSU DENNER GROUP



CHRIS LANGLOIS

Real Estate Advisor
604 312 9322 • chris@chrislanglois.ca

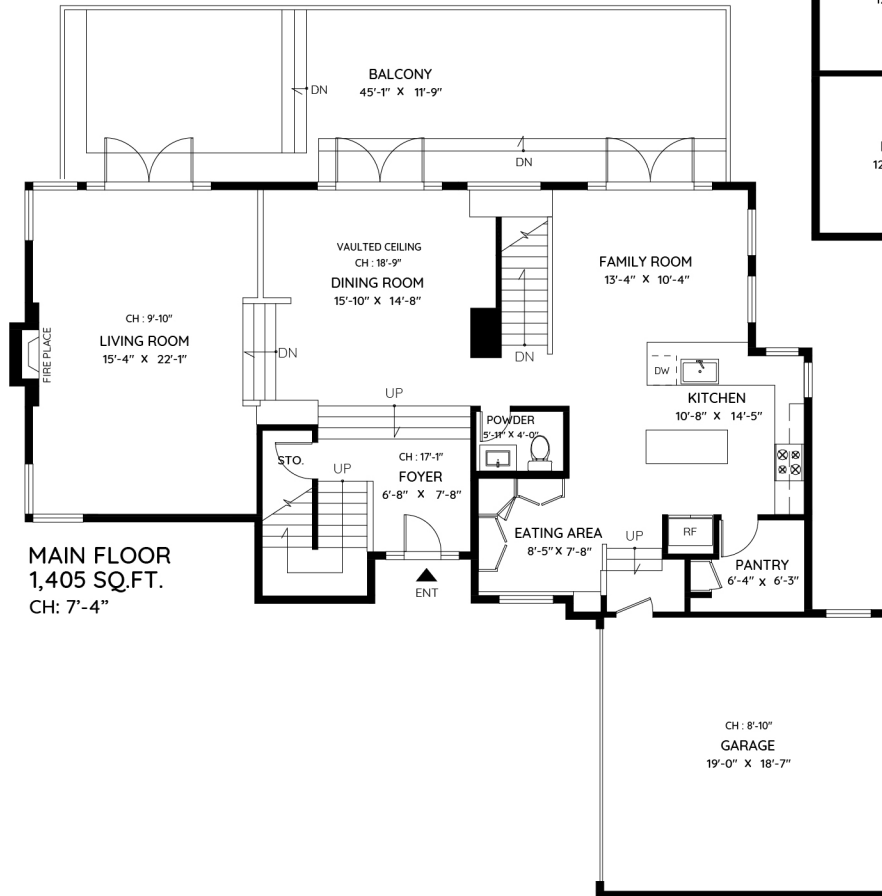
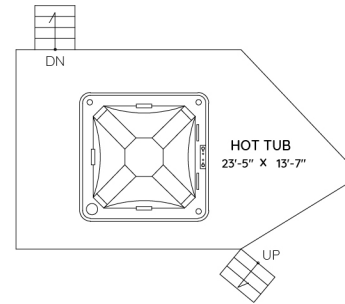

MAIN FLOOR
1,405 SQ.FT.
CH: 7'-4"

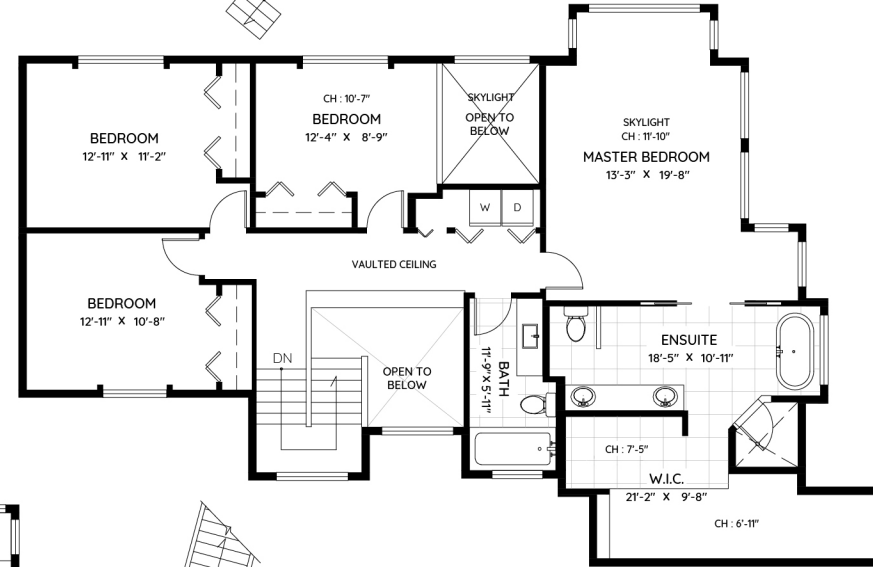

UPPER FLOOR
1,434 SQ.FT.
CH: 11'-3" (Vaulted C.H.)

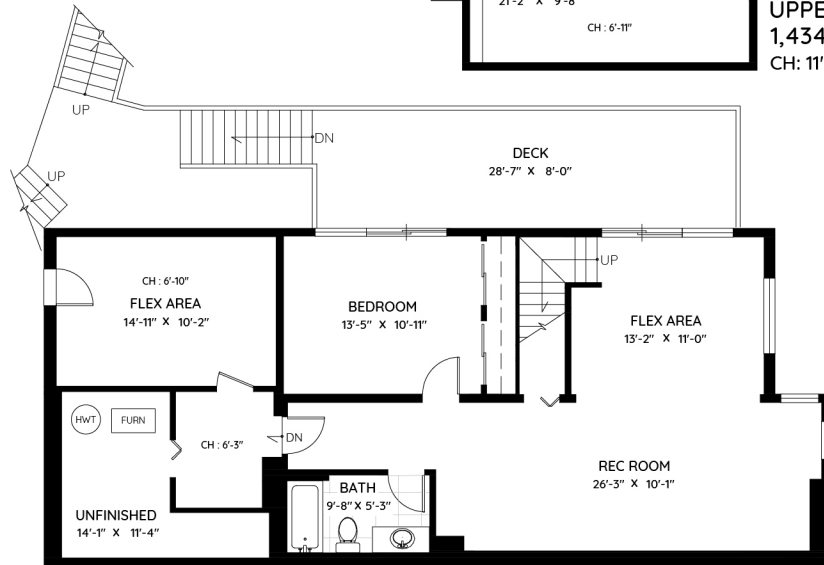

LOWER FLOOR
1,069 SQ.FT.
CH: 7'-10"



The floor plan and the measurements are approximate and are to be used for advertising usage only. Not suitable for architectural or construction. E&O Insured